



LED spotlight C2-STT-M with triple lens

part number: A400464

description:

LED spotlight for track Multisystem EVO,
360° rotatable, ~160° swivelling

housing colour:

aluminum anodised matte in black
or powder-coated in white RAL 9016

optics:

13°, 25°, 42°, 50°
incl. light diffusion foil

light colour (+/- 100K):

~2,700 K, ~3,000 K, ~3,500 K, ~4,000 K, ~5,700 K

3 high power LED, high CRI DIN EN 55015:2019,
lifetime 50,000 hours | basis of lifetime L80B10

protection class:

IP 20, protection class III, CE

luminous flux (~3,000 K | 25° | 1000 mA):

~630 lm at ~9 W (70 lm/W)

power input: 48V DC (constant voltage)**allowed power supplies:**

power supplies of ELG series by MeanWell
with constant voltage 48V DC
(other power supplies on request)

dimming:

DALI or Casambi

accessories:

suitable for track type
Multisystem EVO A.A.G. Stucchi 48V

optional accessories:

honeycomb grid

dimensions

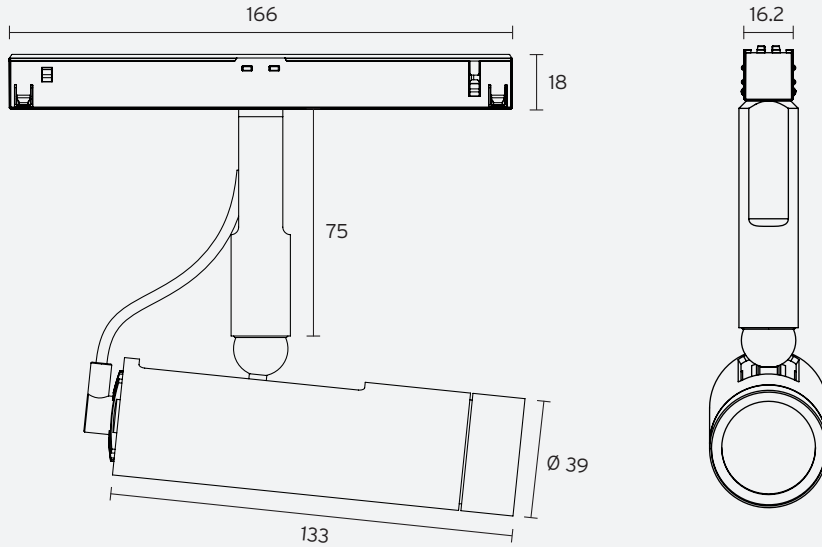

specification in mm

photometry

light colour ~3,000K | standard lens 25° | CRI typ. 97, R9 > 90, R12 > 90 | colour variation ≤ 3 SDCM | distance ~60 cm

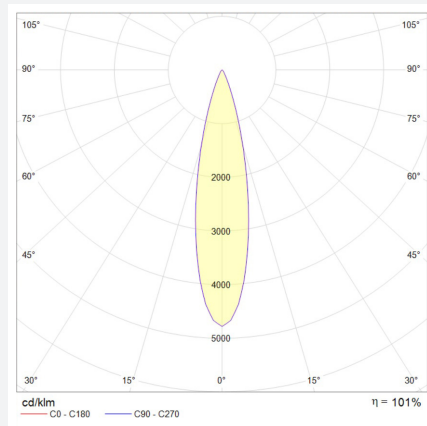
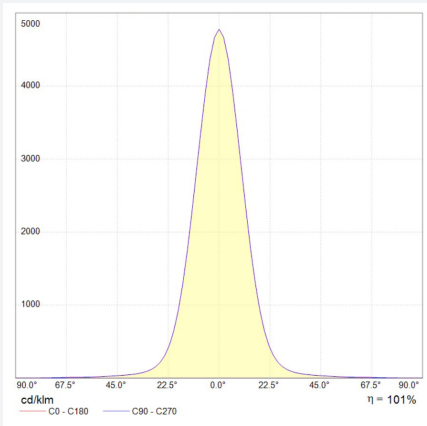

technical changes reserved | January 2025